

TITLE: fFEX Block_BB_V17	
Document Number:	REV: BB
Date: 02.02.2024 11:09:18	Sheet: 2/10

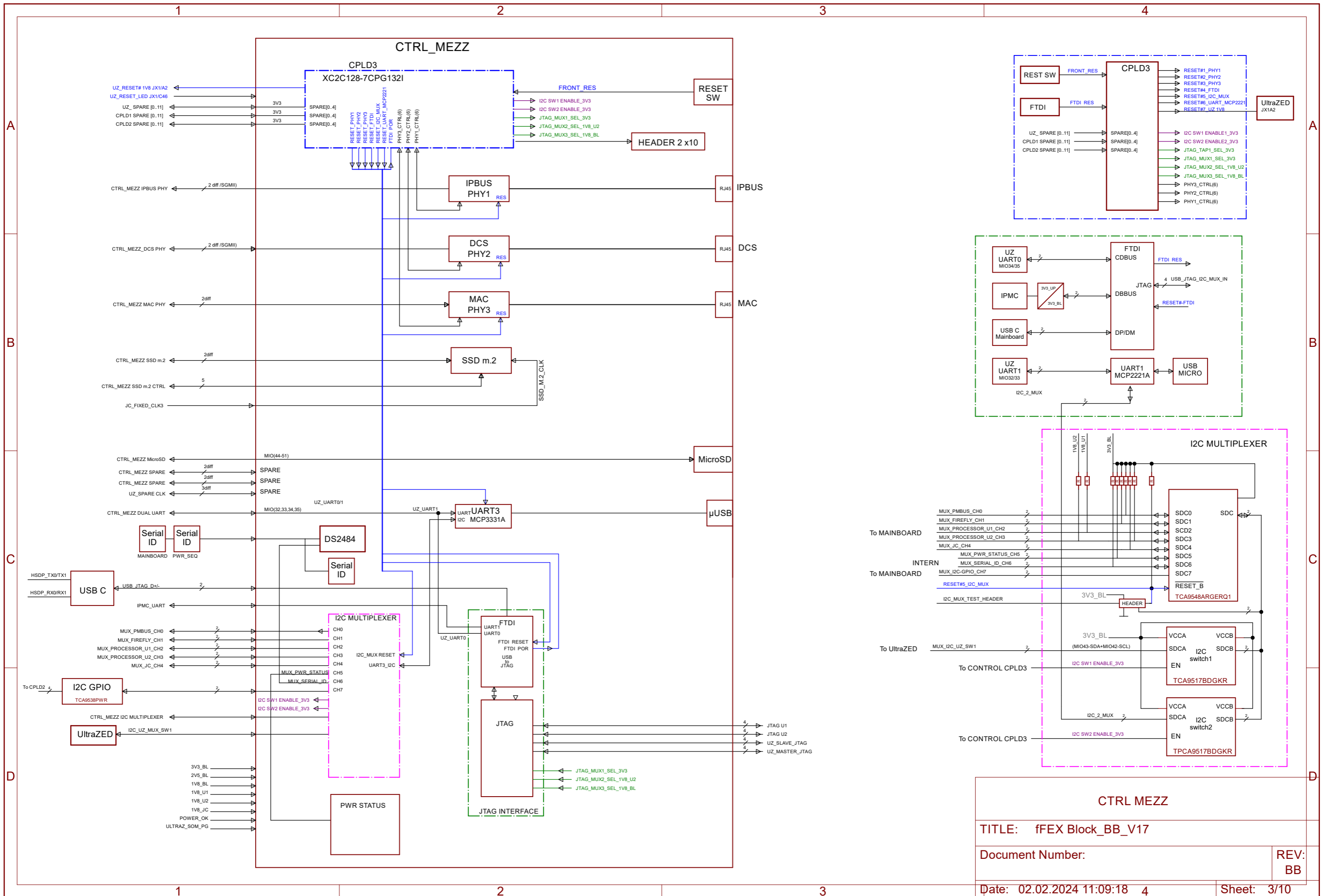

TITLE: fFEX Block_BB_V17

Document Number:

REV:
BB

Date: 02.02.2024 11:09:18

Sheet: 3/10

JITTER CLEANER I2C

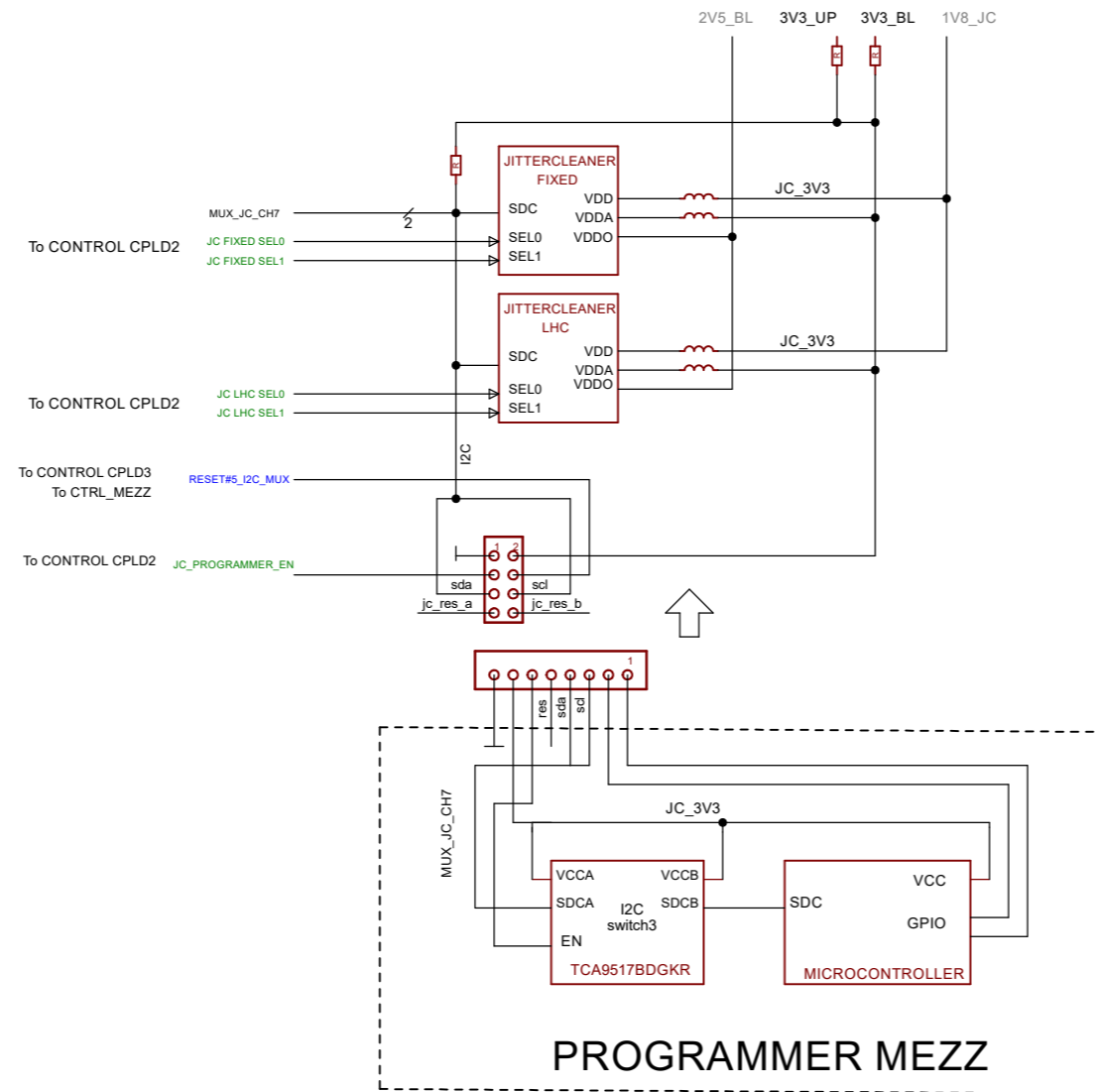

Jitter Cleaner	
TITLE: fFEX Block_BB_V17	
Document Number:	REV: BB
Date: 02.02.2024 11:09:18 4	Sheet: 4/10

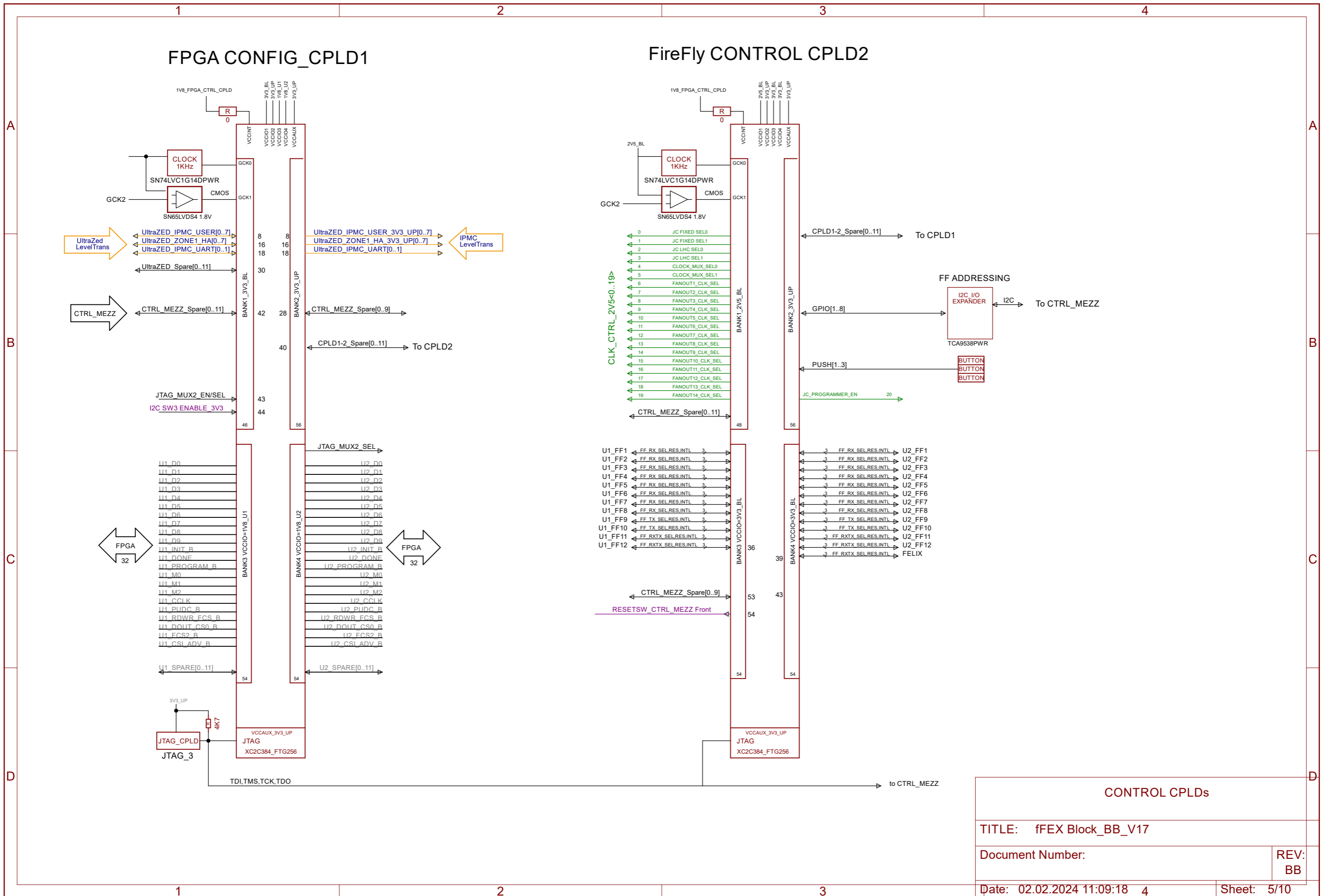

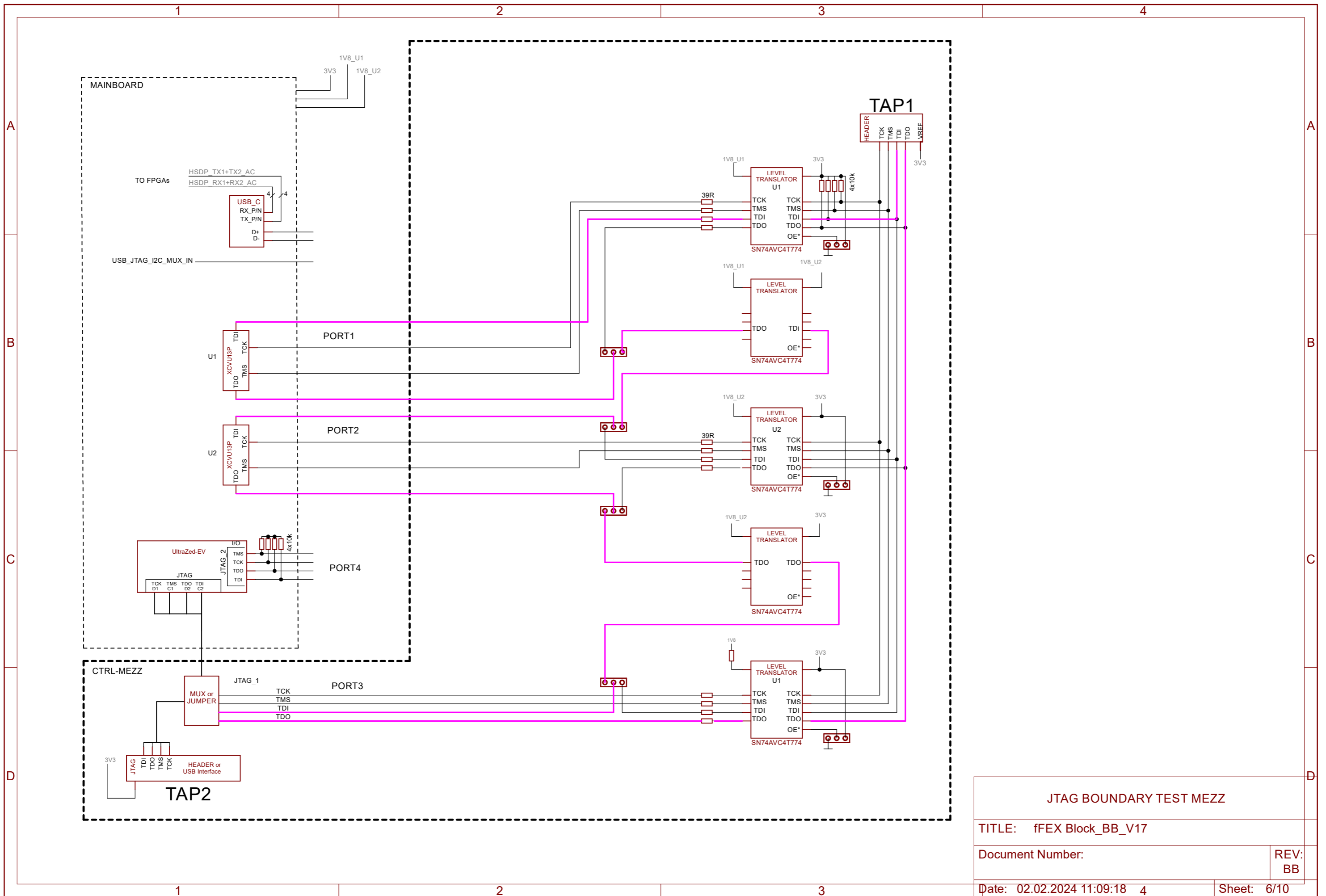

JTAG BOUNDARY TEST MEZZ

TITLE: fFEX Block_BB_V17

Document Number:

REV:
BB

Date: 02.02.2024 11:09:18 4

Sheet: 6/10

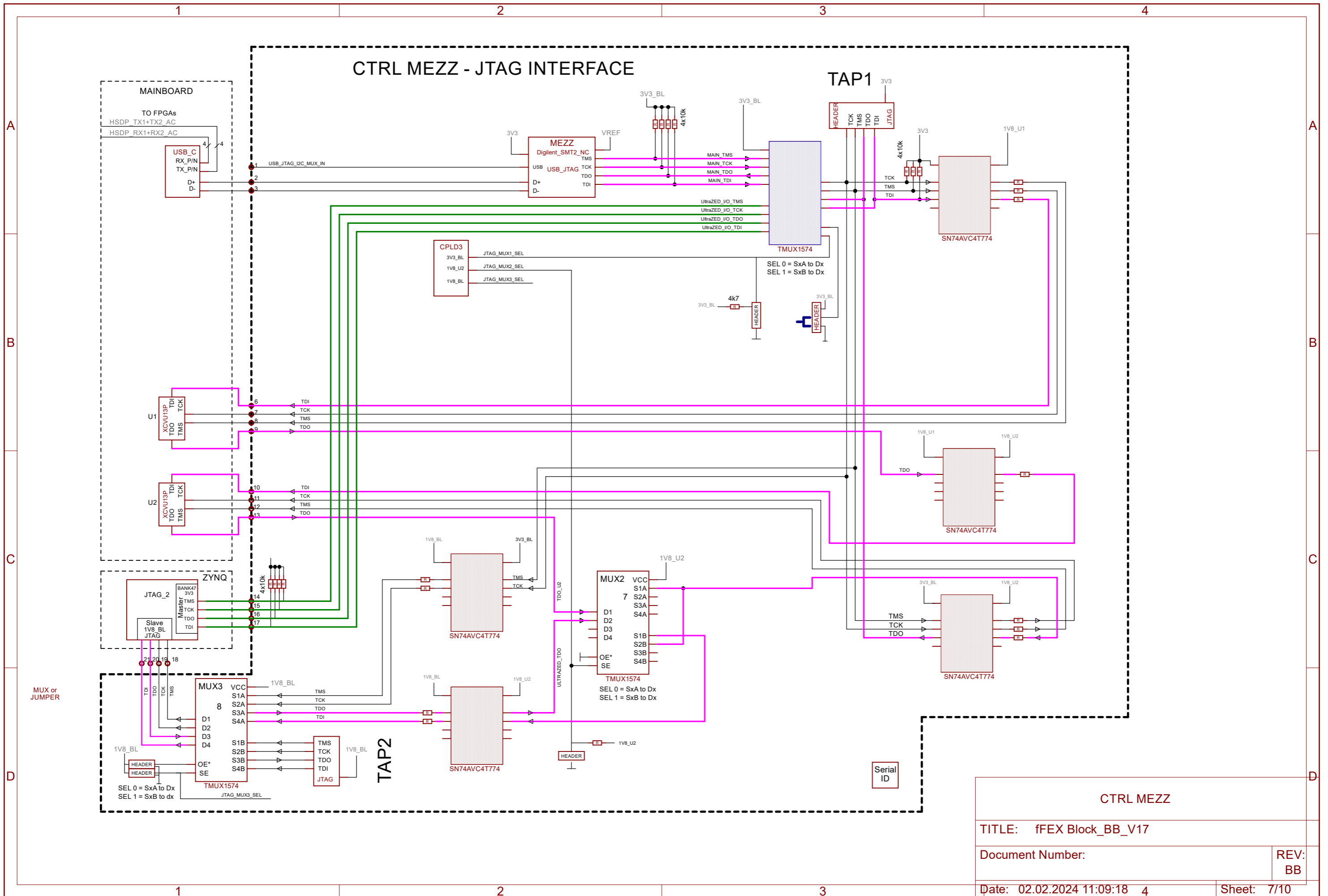

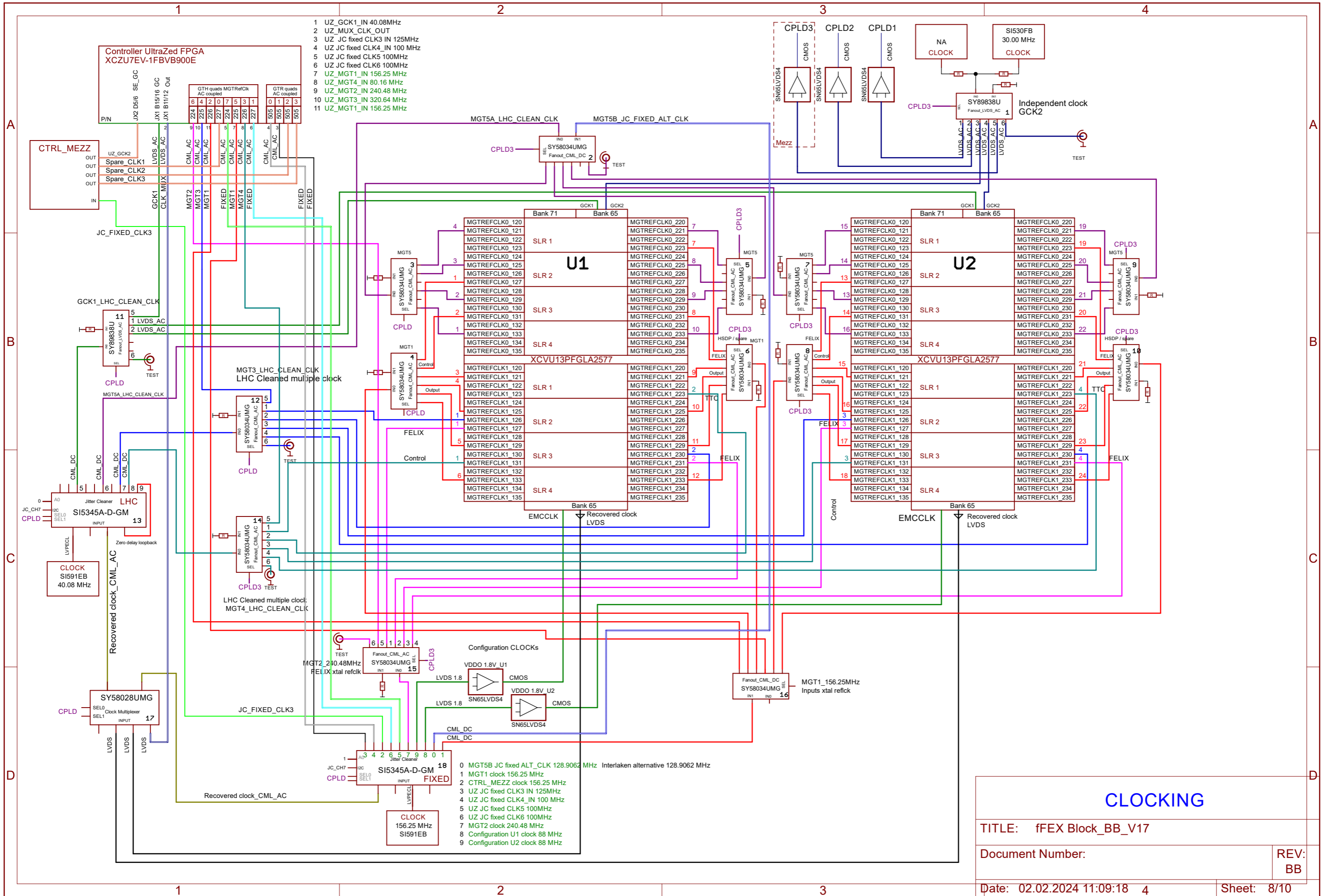

CLOCKING

TITLE: fFEX Block_BB_V17

Document Number:

REV:
BB

Date: 02.02.2024 11:09:18

Sheet: 8/10

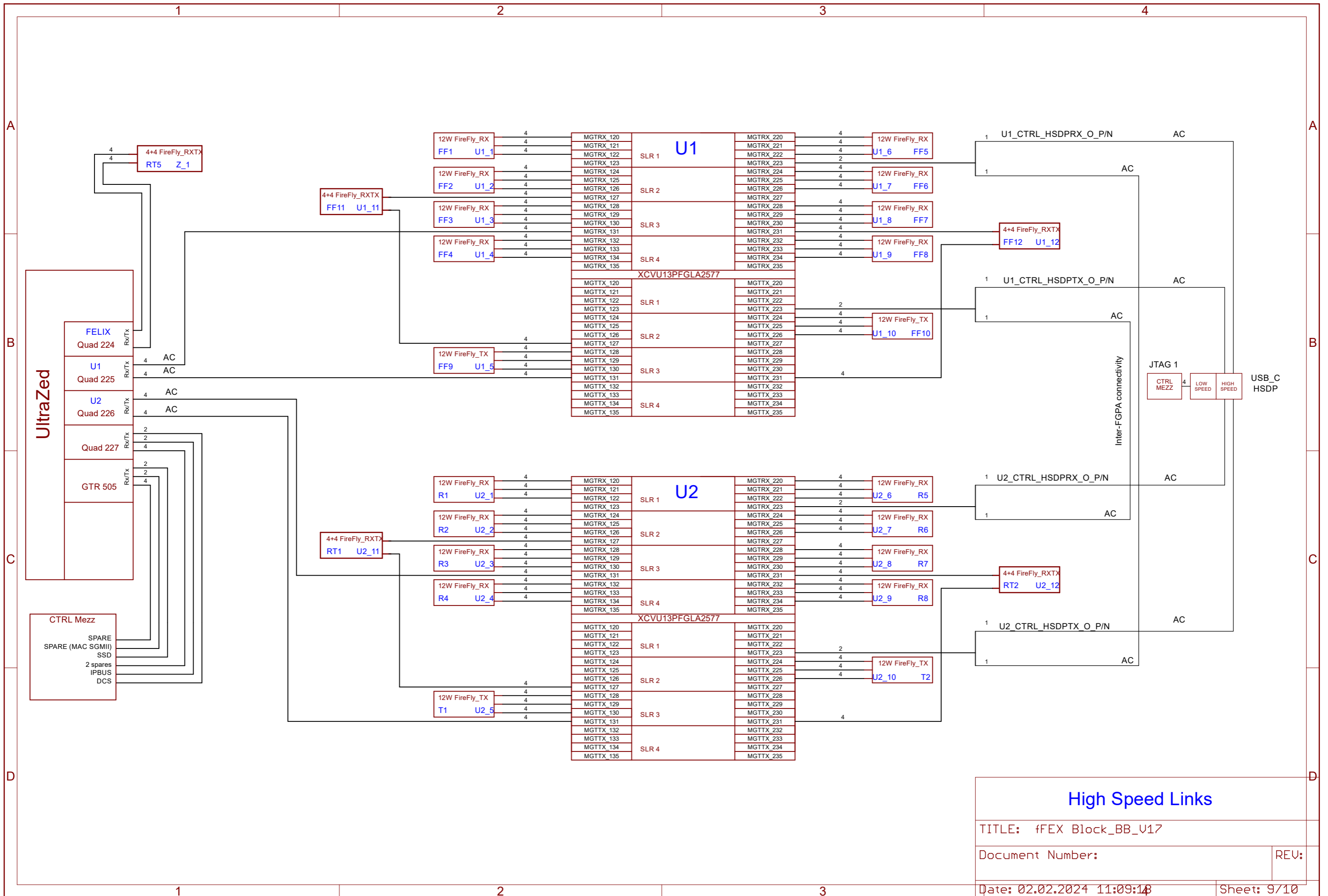

High Speed Links	
TITLE: fFEX Block_BB_U17	
Document Number:	REV:
Date: 02.02.2024 11:09:18	Sheet: 9/10

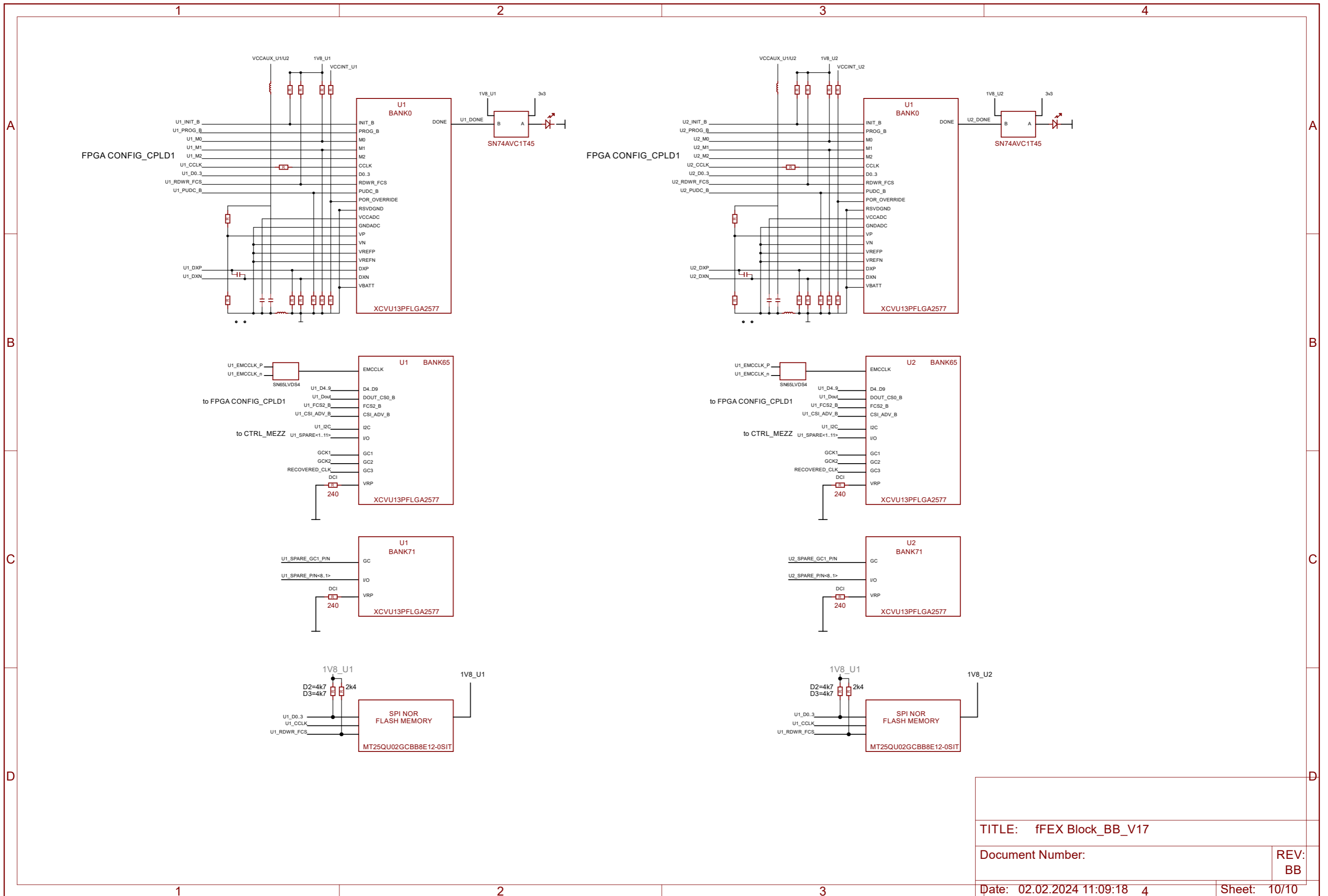

TITLE: fFEX Block_BB_V17

Document Number:

REV:
BB

Date: 02.02.2024 11:09:18 4

Sheet: 10/10